

*[Handwritten signature]*

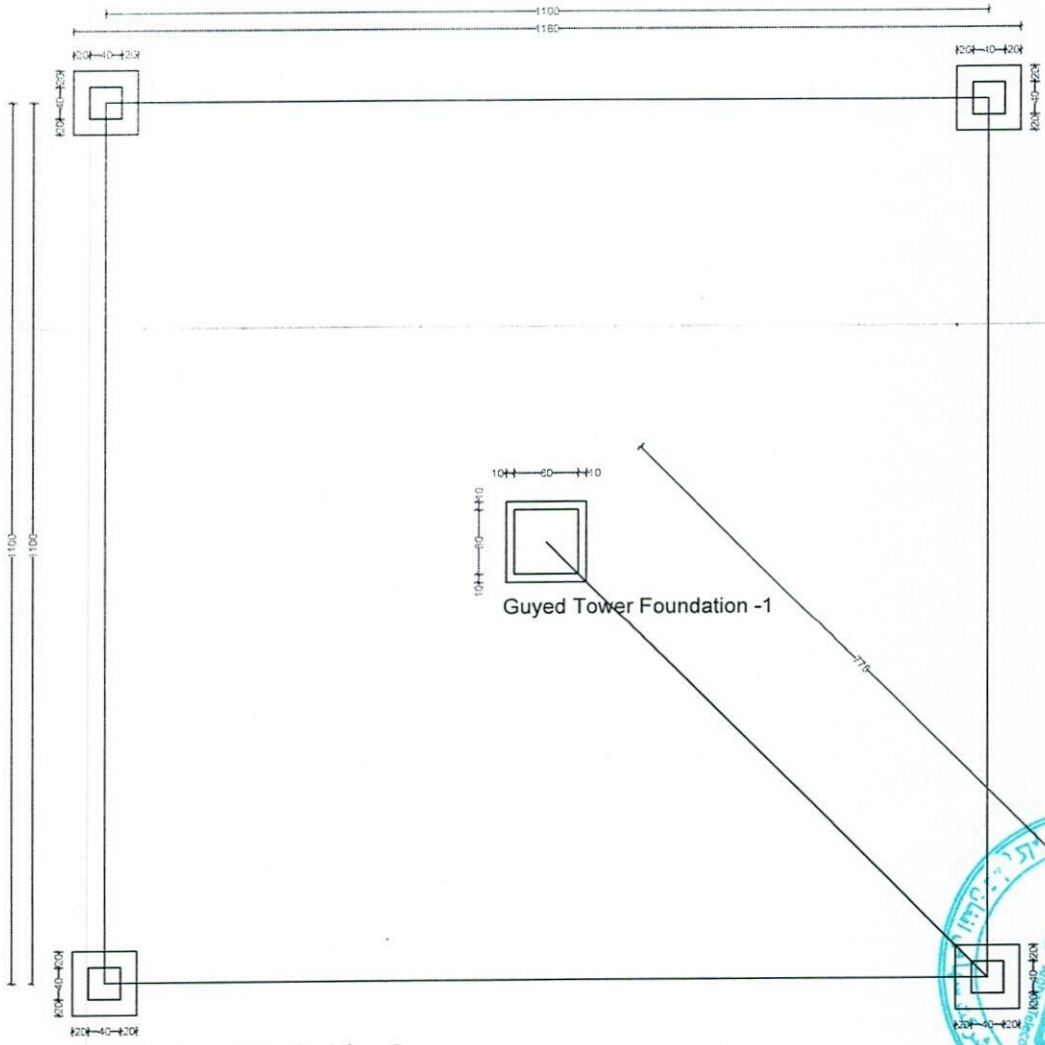

Foundation For Cable -2

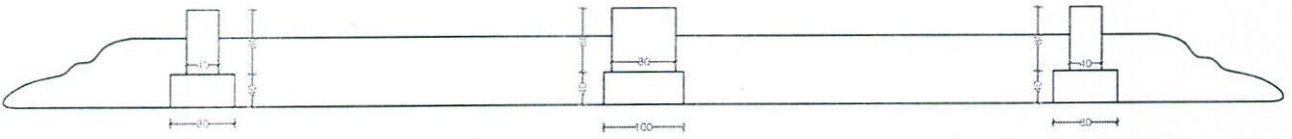

*[Handwritten signature in blue ink]*

# Guyed Tower Foundation -1

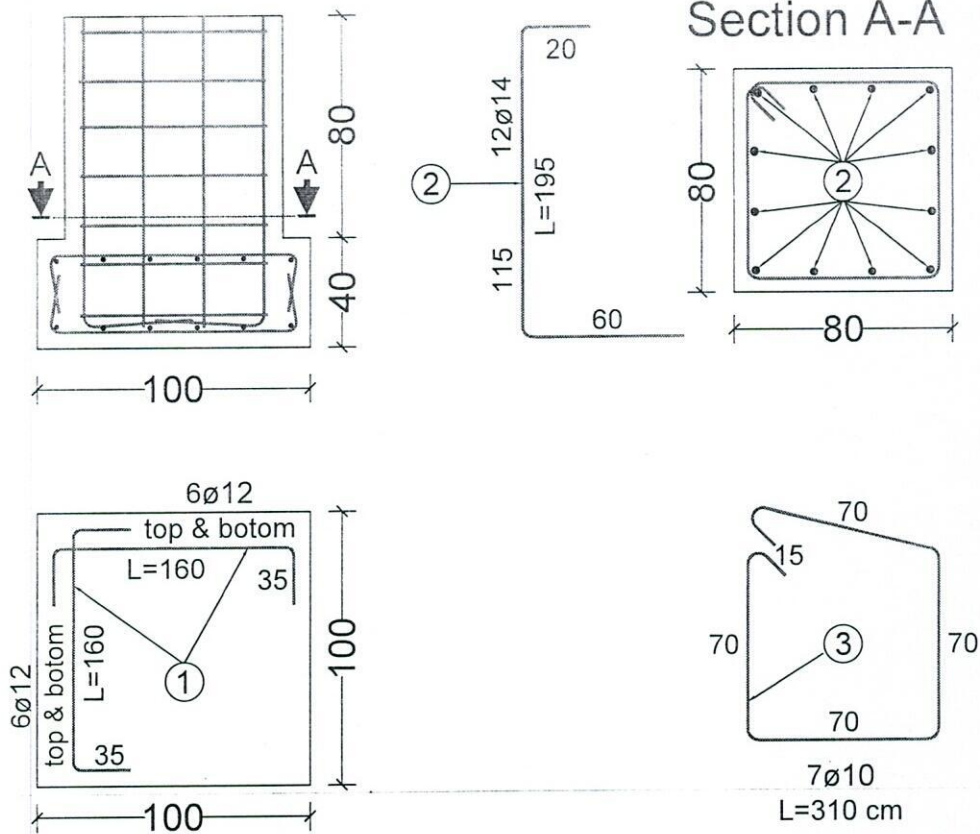

15m - Guyed Tower Foundation -1 (For One Foundation)					
BAR TYPE	DIA (mm)	LENGHT (cm)	NO OF BARS	UNIT WT (kg/m)	TOTAL WT (kg)
1	Ø12	160	24	0.89	34.18
2	Ø14	195	12	1.21	28.31
3	Ø10	310	7	0.62	13.45
TOTAL WEIGHT OF STEEL. (kg)					75
LEAN CONCRETE VOLUME. (Cu.m)					0.12
REINFORCED CONCRETE VOLUME. (Cu.m)					0.912
EXCAVATION. (Cu.m)					2.9
REINFORCEMENT STEEL.					S420
CONCRERE.					C20





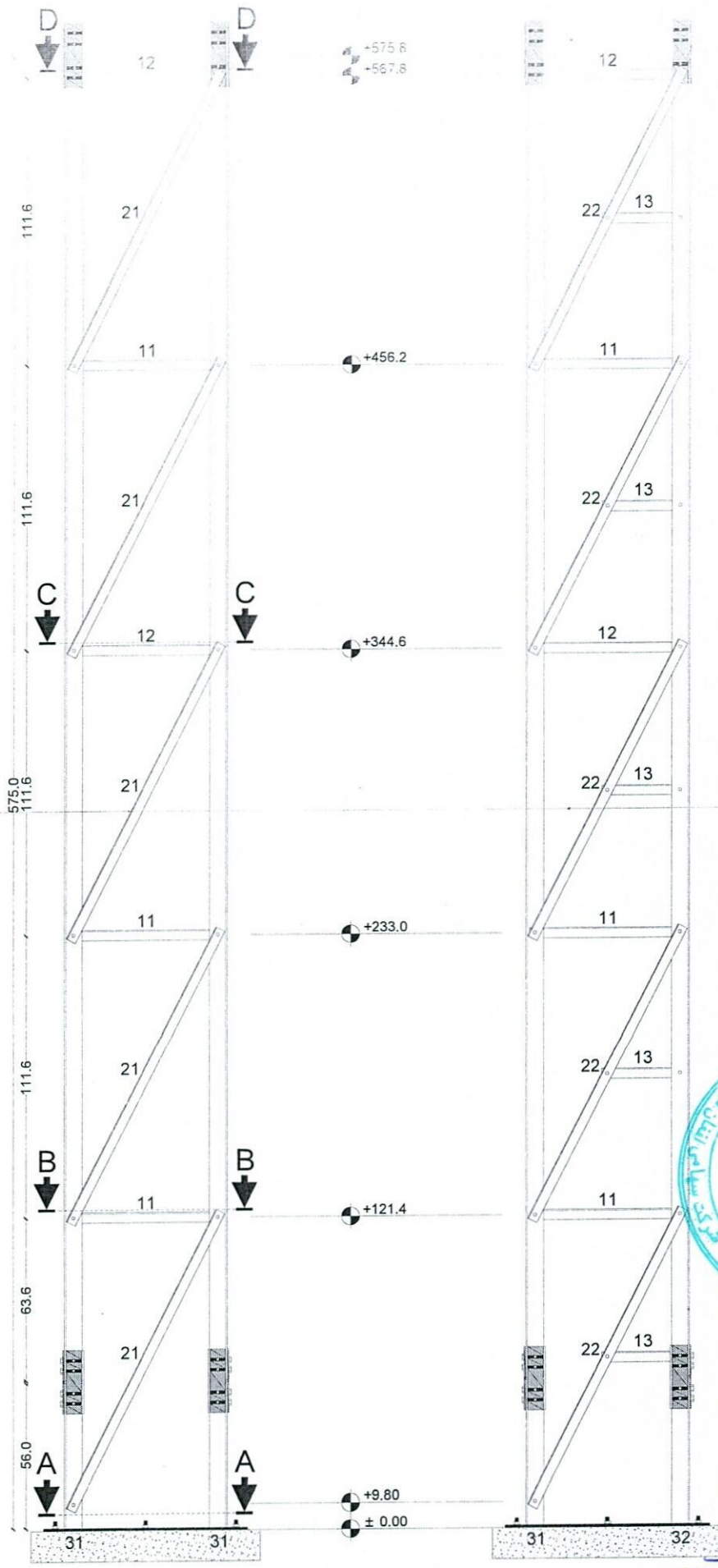

Section (1)

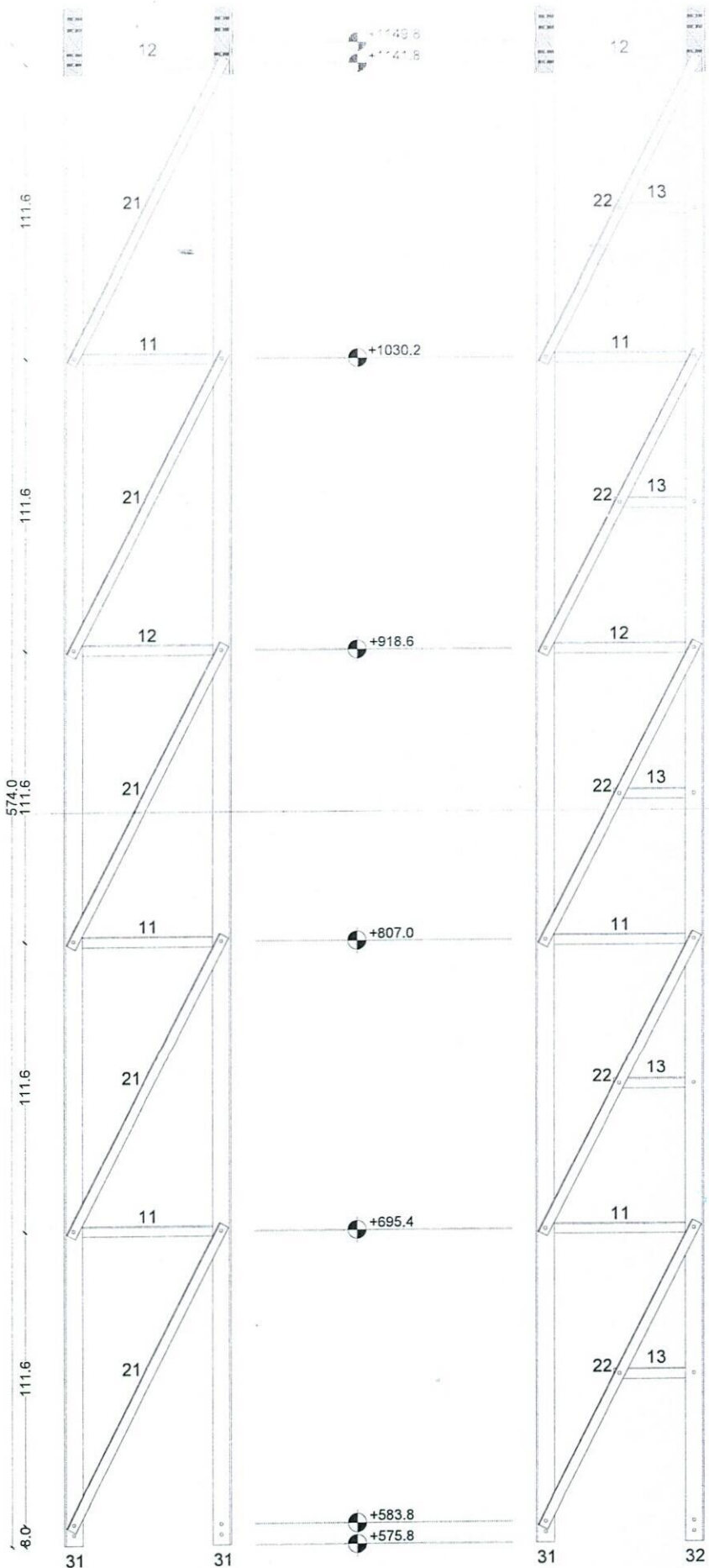

Section (2)



# Parts Detail

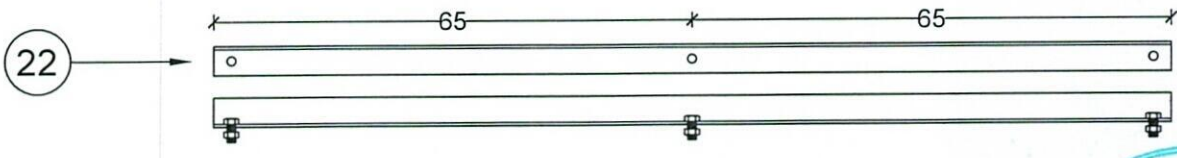
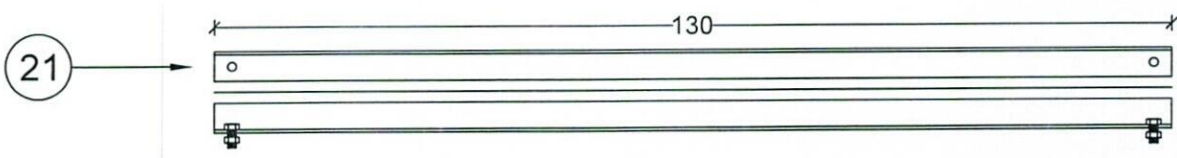
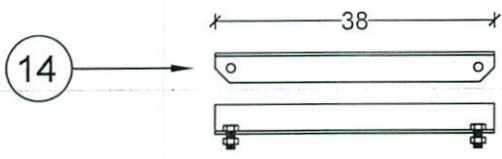
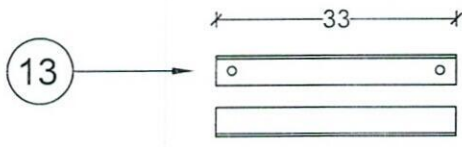
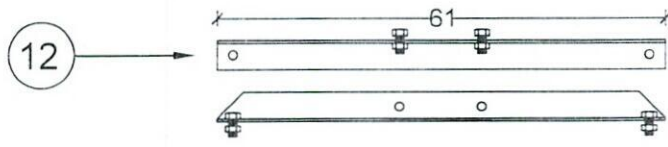
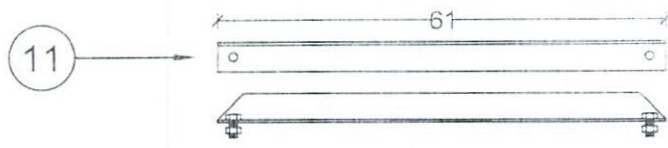



# Section Detail

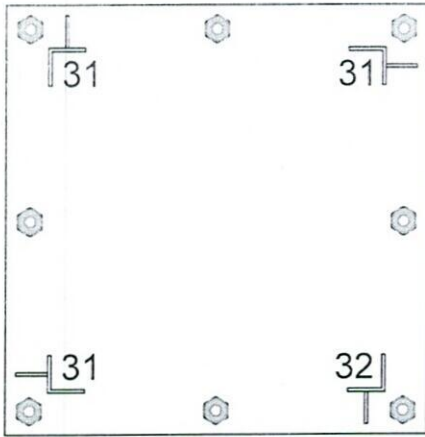

Section A-A  
PL800\*800\*12

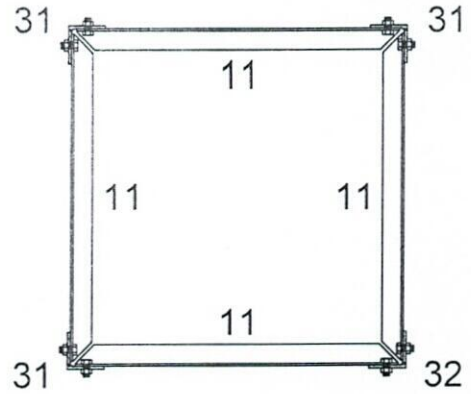

Section B-B

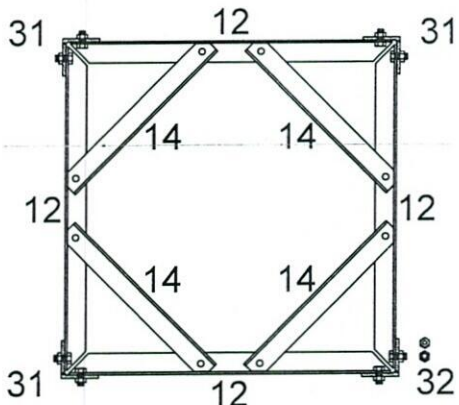

Section C-C

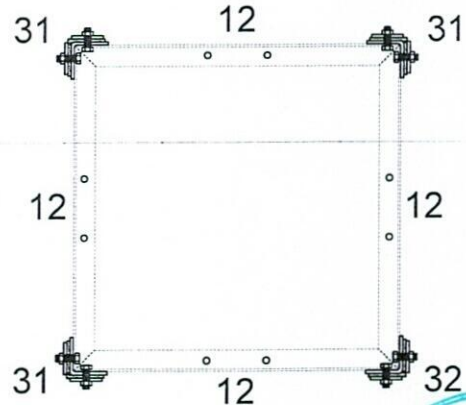

Section D-D

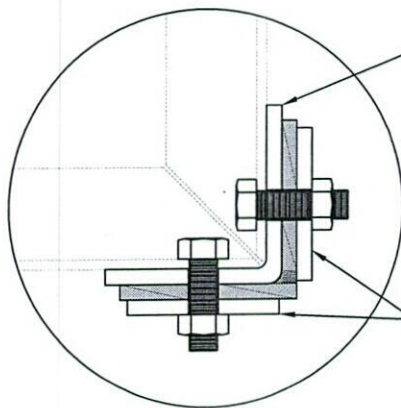

L70\*6

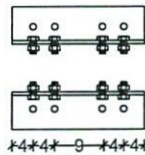

Plate (25\*6)

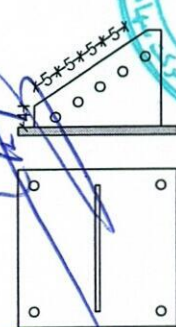
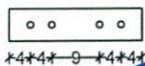
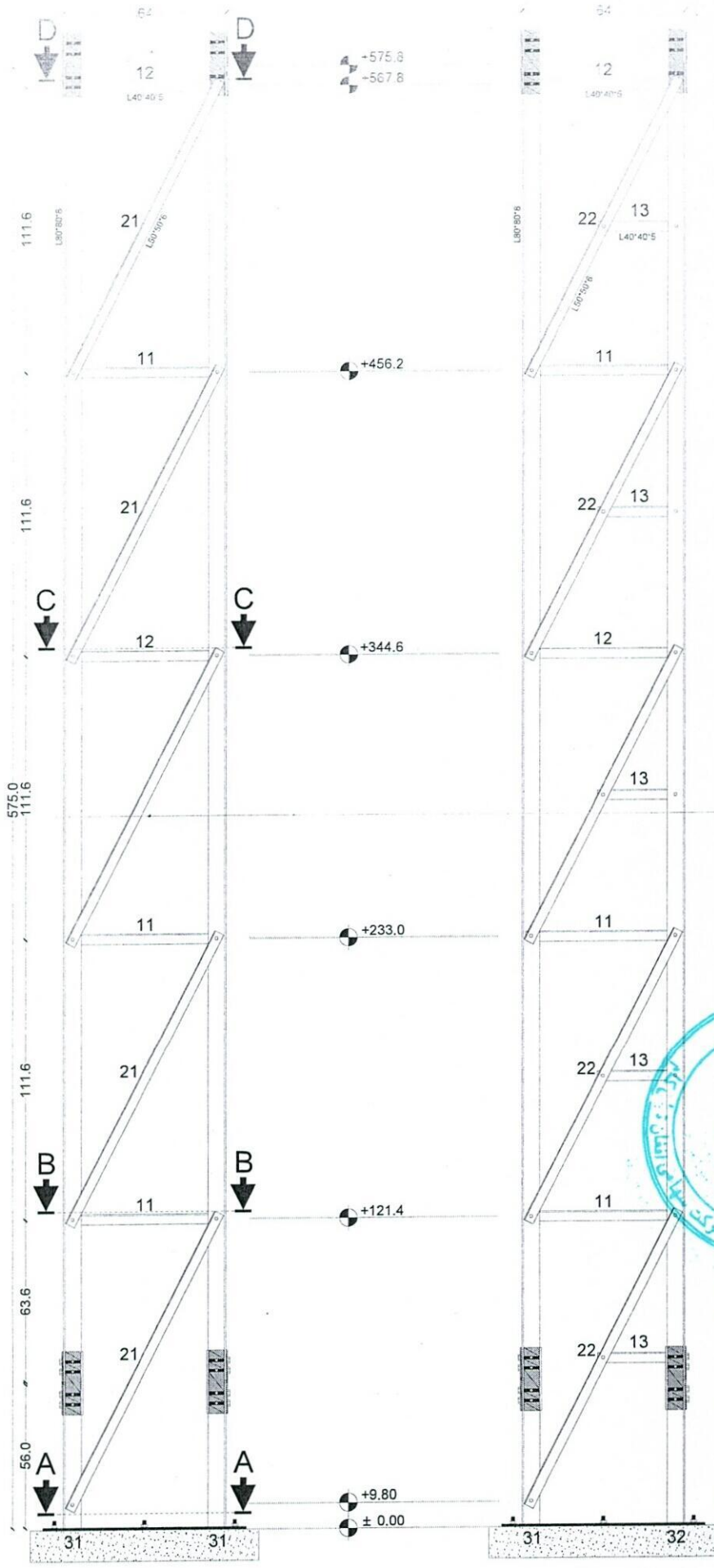

Plate Cable

PL300\*300\*10





Section (1)

MANUFACTURED  
 CLIENT AFGHAN TELECOM  
 TITLE 30M GUYED MAST TOWER



*[Handwritten signature]*

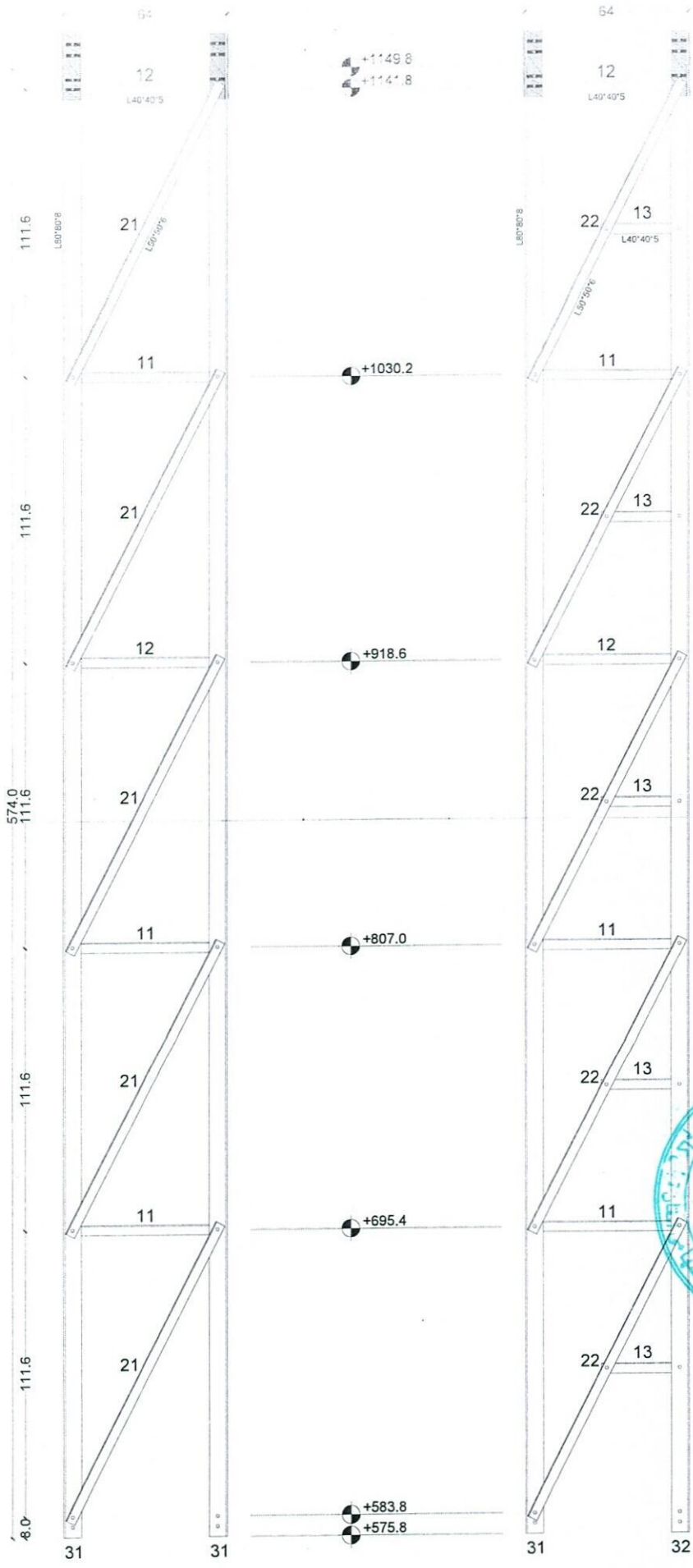

MANUFACTURED  
 CLIENT AFGHAN TELECOM  
 TITLE 30M GUYED MAST TOWER



Section (2)

*[Handwritten signature]*



MANUFACTURED  
 CLIENT AFGHAN TELECOM  
 TITLE 30M GUYED MAST TOWER



Section (3)

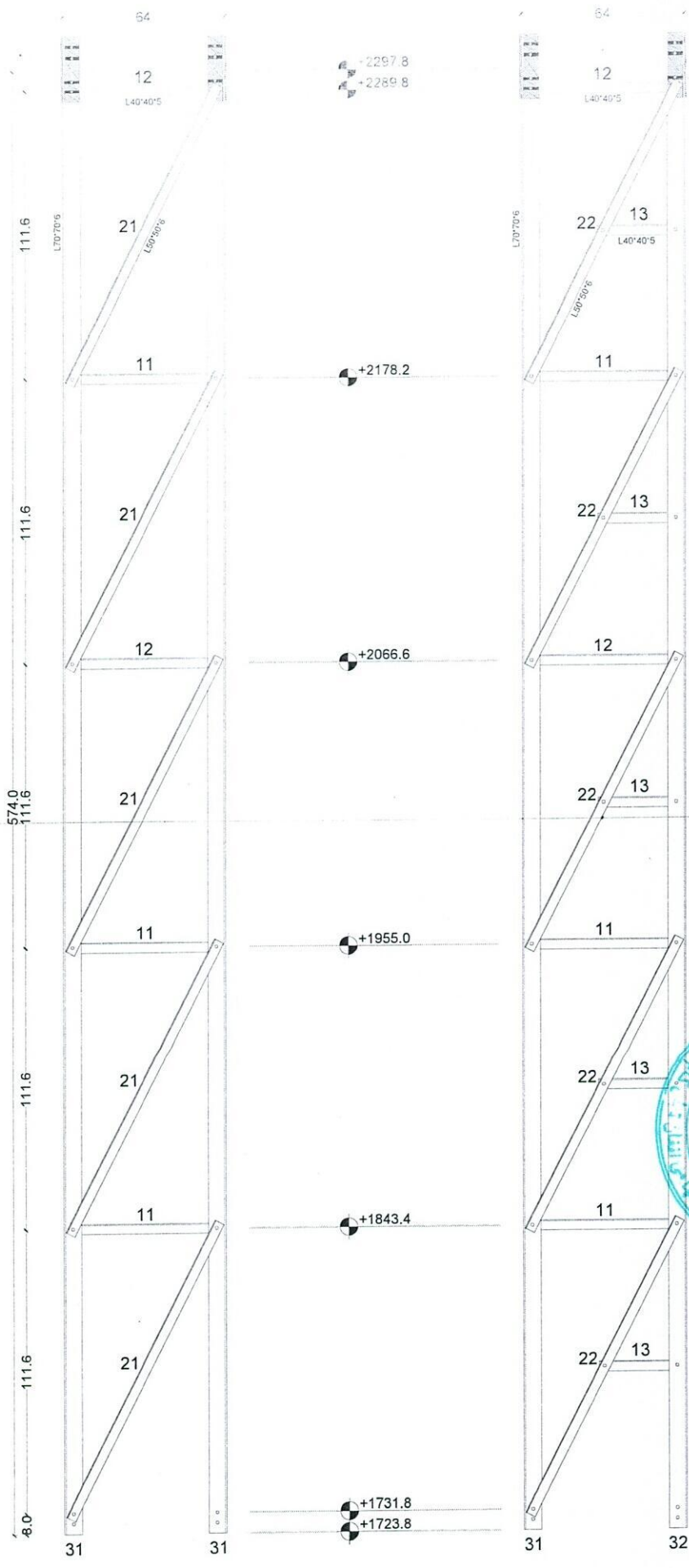

MANUFACTURED  
 CLIENT: AFGHAN TELECOM  
 TITLE: 30M GUYED MAST TOWER

*[Handwritten signature]*



Section (4)

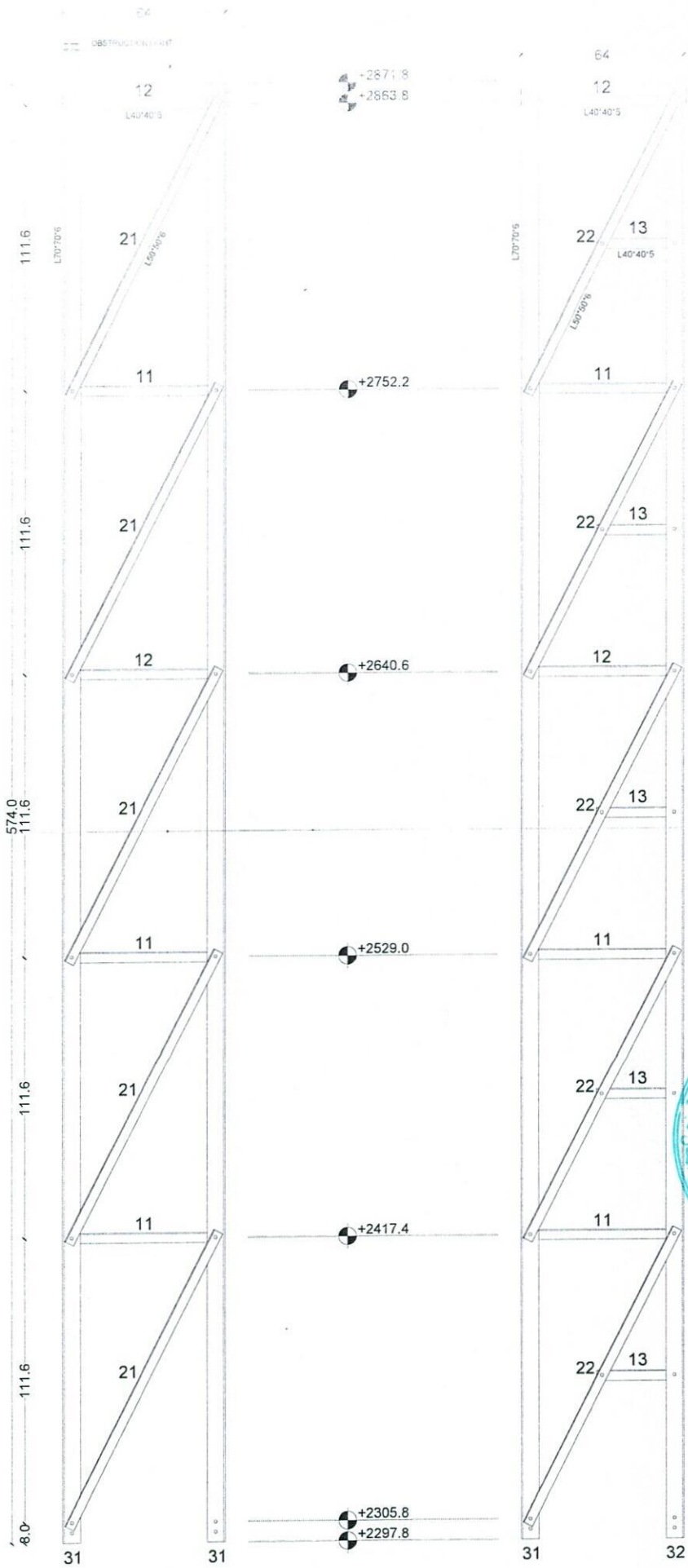

MANUFACTURED  
 CLIENT AFGHAN TELECOM  
 TITLE 30M GUYED MAST TOWER



Section (5)

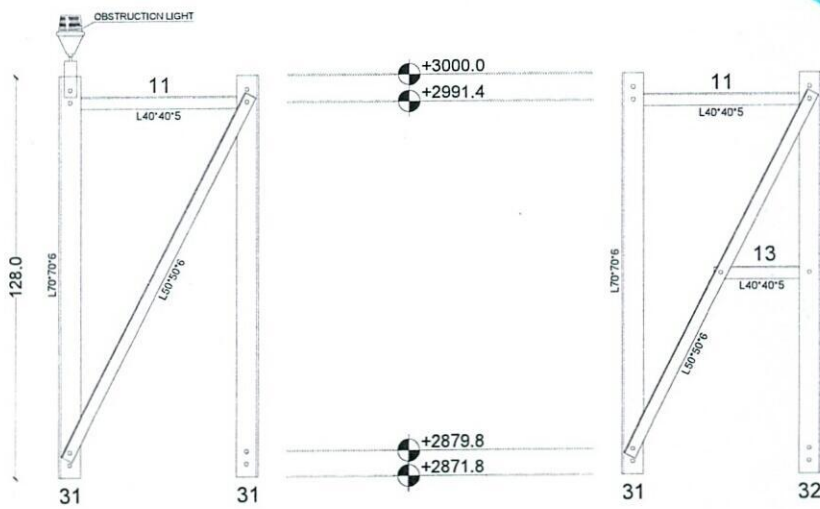

Section (6)



MANUFACTURED

CLIENT AFGHAN TELECOM

TITLE 30M GUYED MAST TOWER

# Section Detail

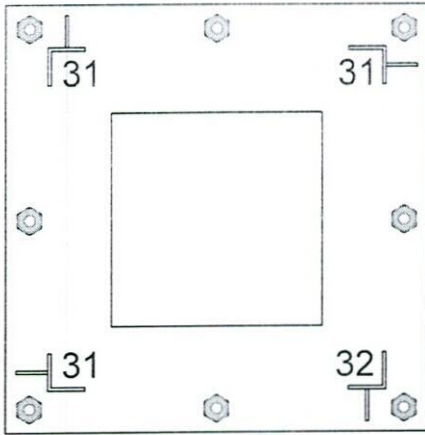

Section A-A  
PL80\*80\*0.8

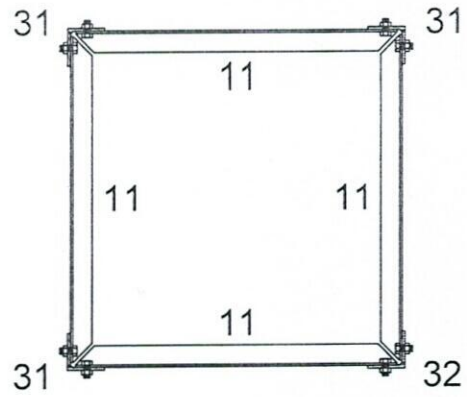

Section B-B

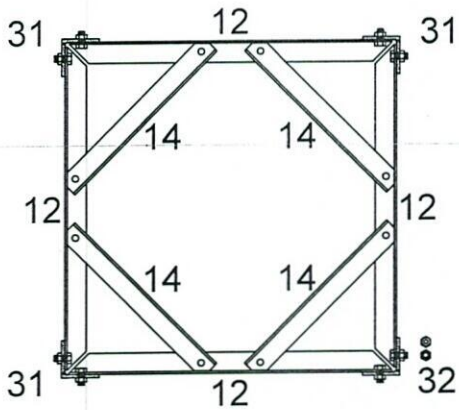
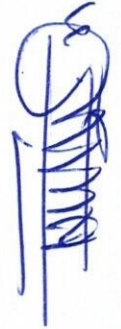

Section C-C

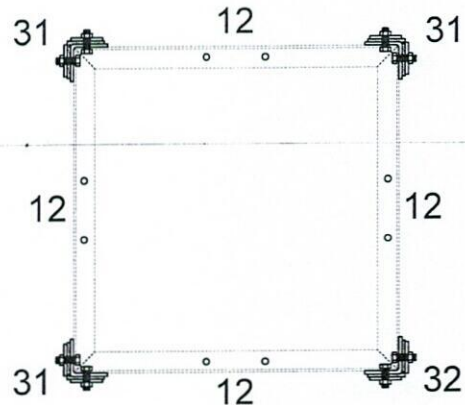

Section D-D

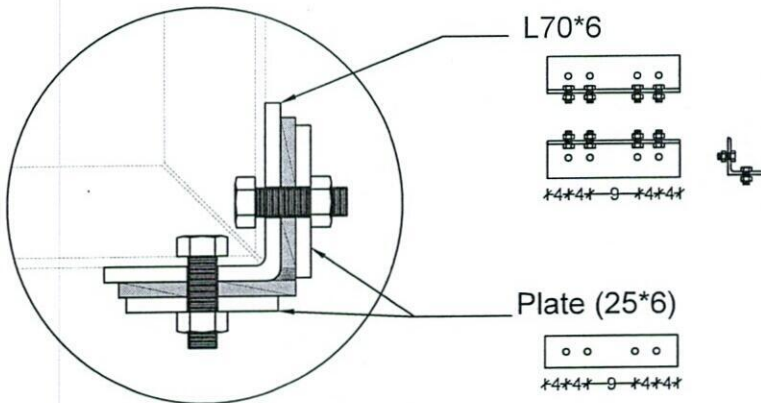

L70\*6

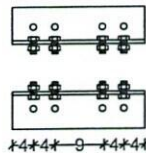
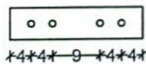
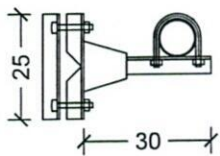
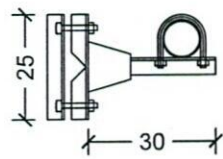
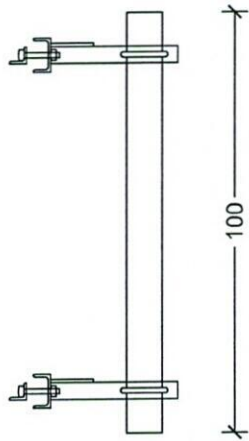

Plate (25\*6)





TYP 1M ANTENNA SUPPORT



TYP 3M ANTENNA SUPPORT

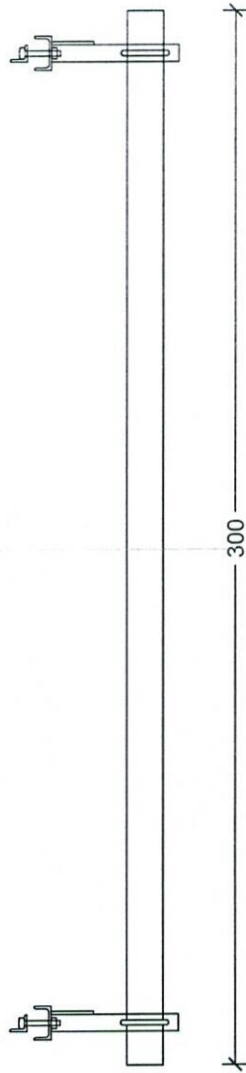

MANUFACTURED	
CLIENT	AFGHAN TELECOM
TITLE	30M GUYED MAST TOWER

# Guyed Tower Foundation -1

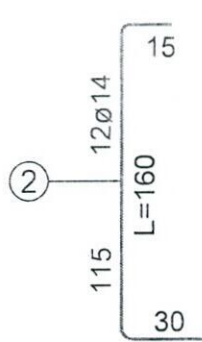
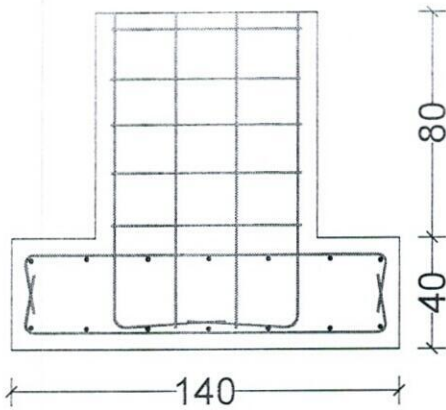

Section A-A

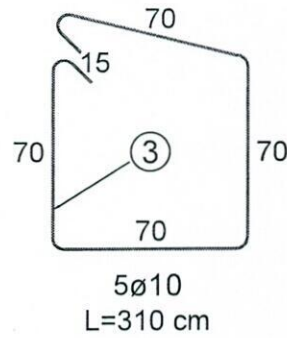
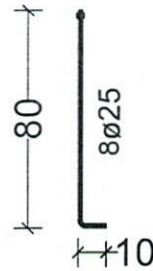
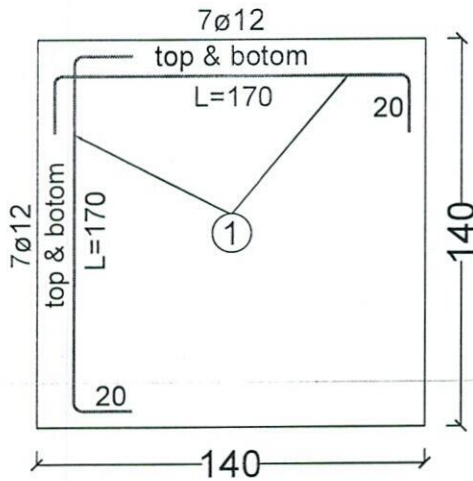
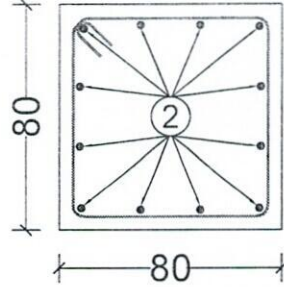

30m - Guyed Tower Foundation -1 (For One Foundation)					
BAR TYPE	DIA (mm)	LENGHT (cm)	NO OF BARS	UNIT WT (kg/m)	TOTAL WT (kg)
1	ø12	170	28	0.89	34.18
2	ø14	160	12	0.89	20.83
3	ø10	310	5	0.62	13.45
TOTAL WEIGHT OF STEEL. (kg)					69
LEAN CONCRETE VOLUME. (Cu.m)					0.12
REINFORCED CONCRETE VOLUME. (Cu.m)					0.91
EXCAVATION. (Cu.m)					2.55
REINFORCEMENT STEEL.					S420
CONCRERE.					C20



*Handwritten signature*

# Foundation For Cable - 2

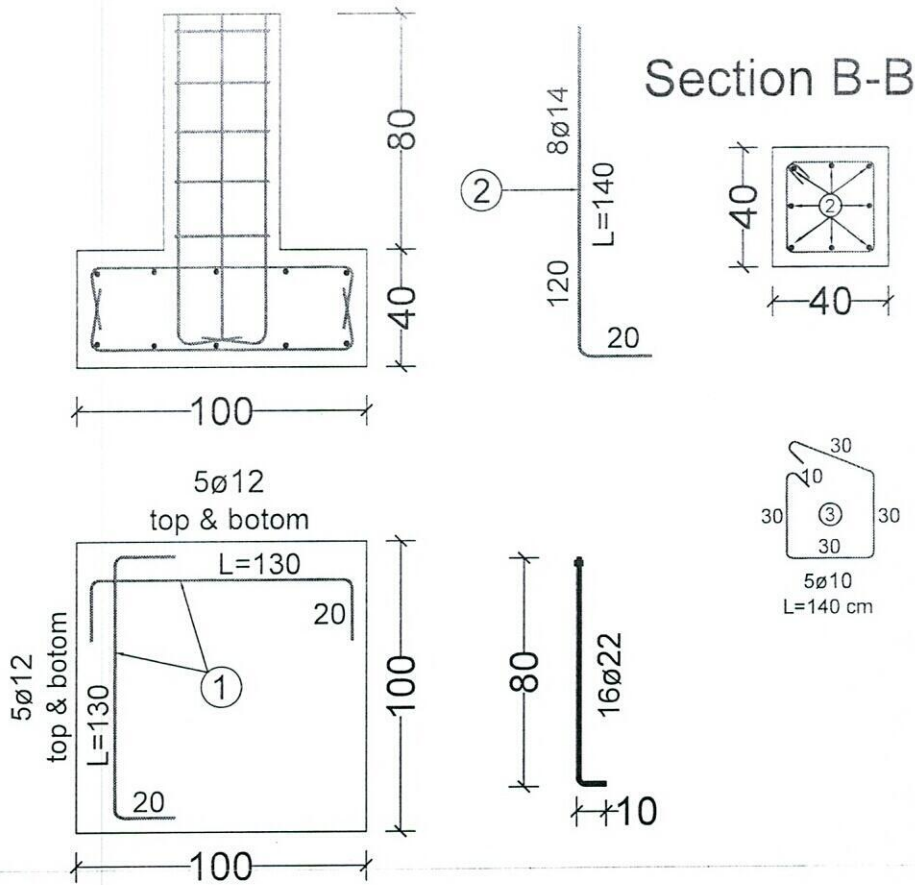

30m - Guyed Tower Foundation -1 (For One Foundation)					
BAR TYPE	DIA (mm)	LENGHT (cm)	NO OF BARS	UNIT WT (kg/m)	TOTAL WT (kg)
1	Ø12	130	20	0.89	19.94
2	Ø14	140	8	0.89	10.32
3	Ø10	140	5	0.62	6.08
TOTAL WEIGHT OF STEEL. (kg)					36
LEAN CONCRETE VOLUME. (Cu.m)					0.12
REINFORCED CONCRETE VOLUME. (Cu.m)					0.4
EXCAVATION. (Cu.m)					1.87
REINFORCEMENT STEEL.					S420
CONCRERE.					C20

Handwritten signatures and initials in blue ink are present on the right side of the page, including one that appears to be 'S.M. Per'.

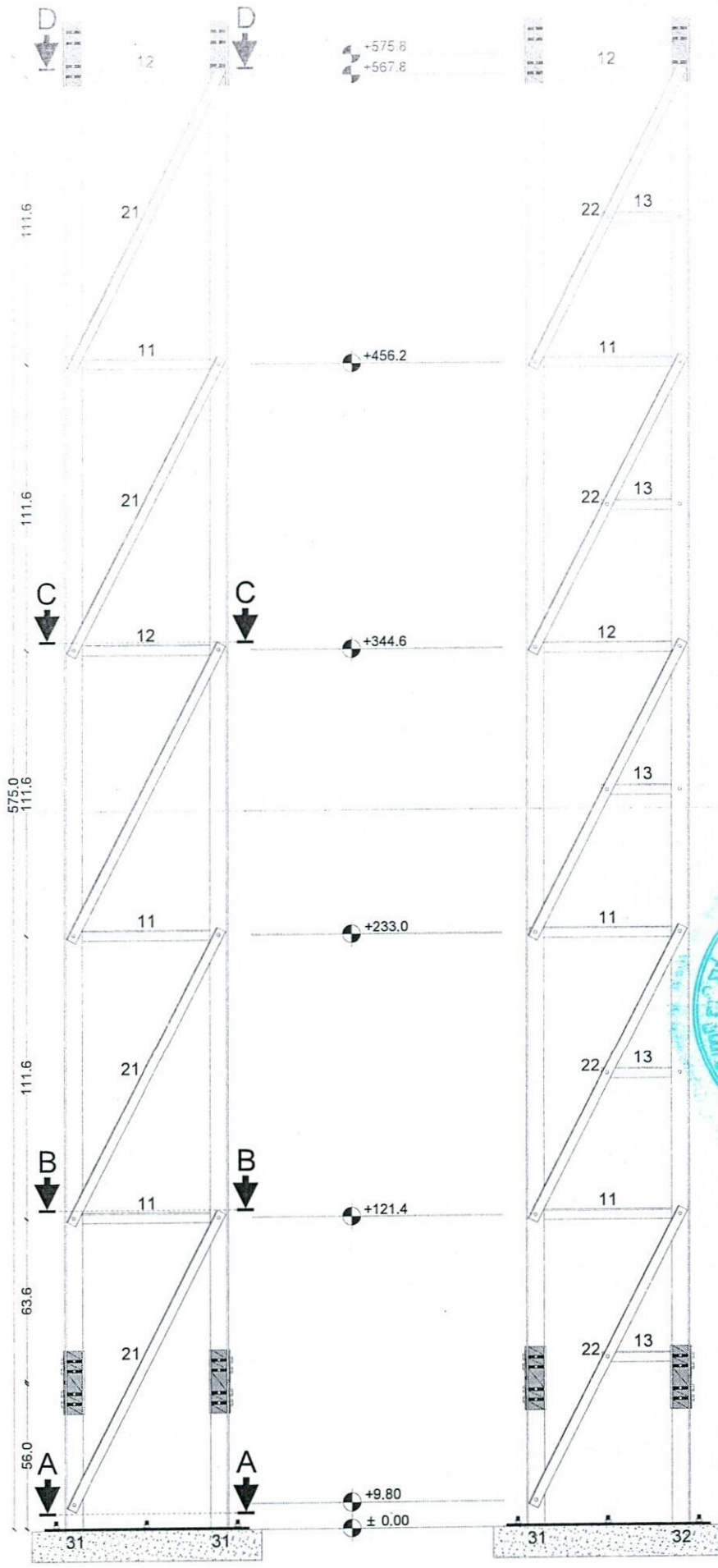

Section (1)

A handwritten signature in blue ink, likely of an engineer or architect, located below the section label.



Section (2)

A handwritten signature in blue ink, likely of the engineer or architect responsible for the drawing.

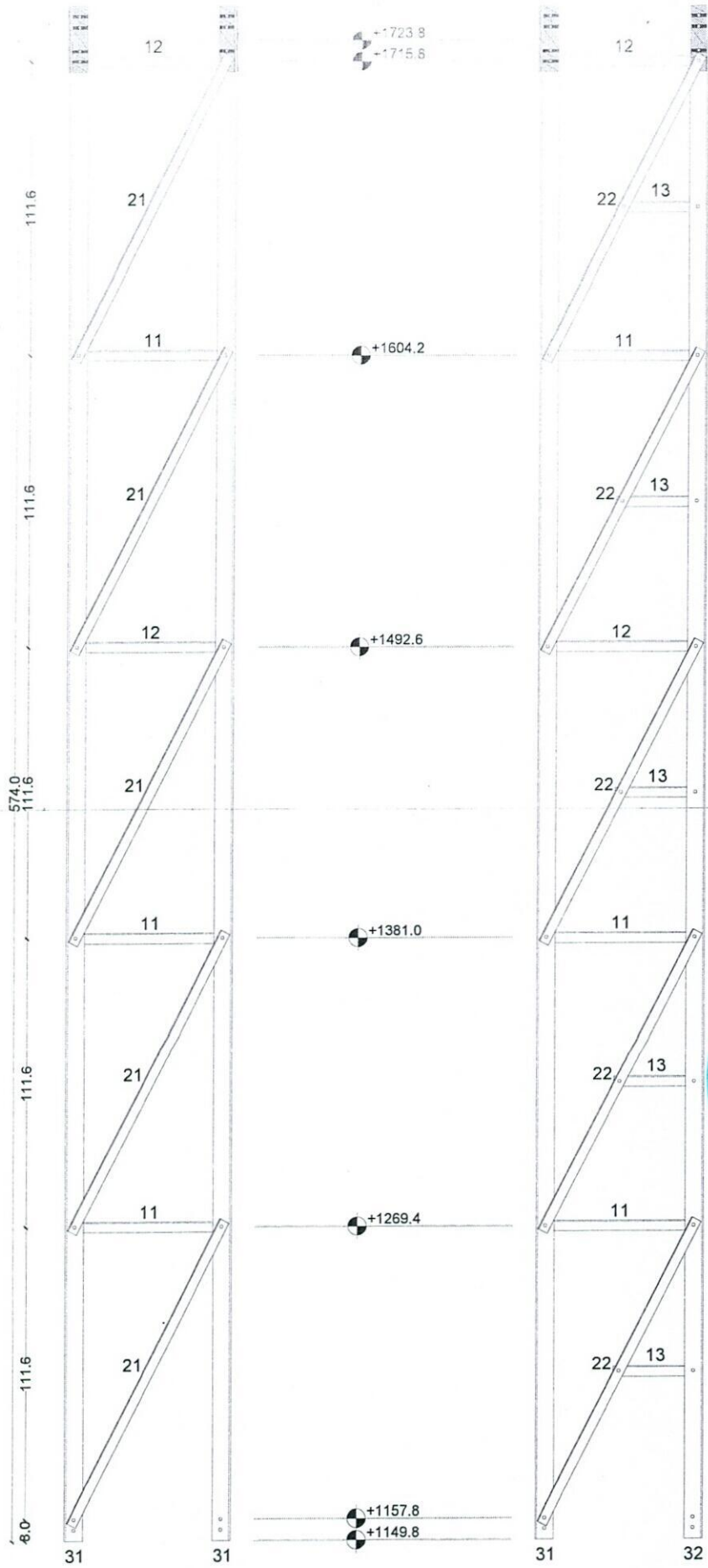

Section (3)

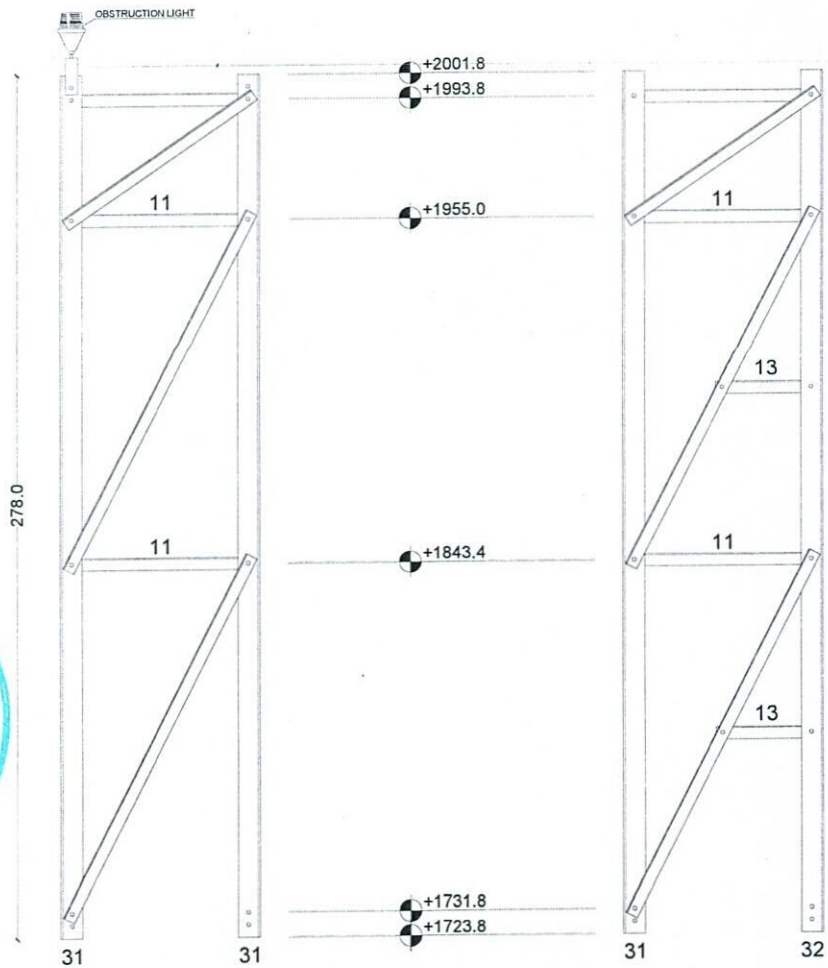

Section (4)

# Parts Detail

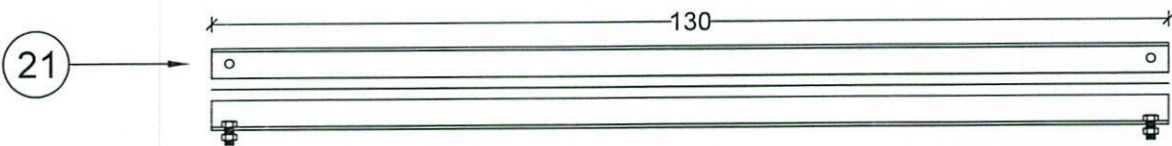
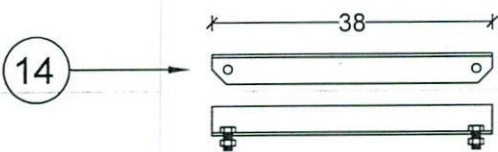
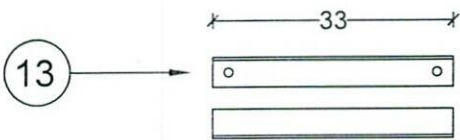
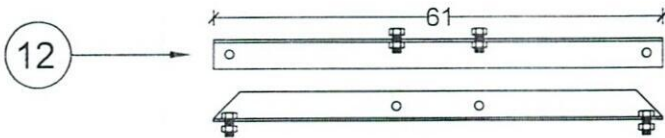
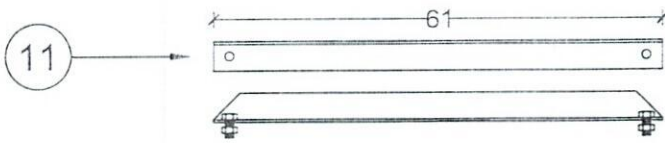

# Section Detail

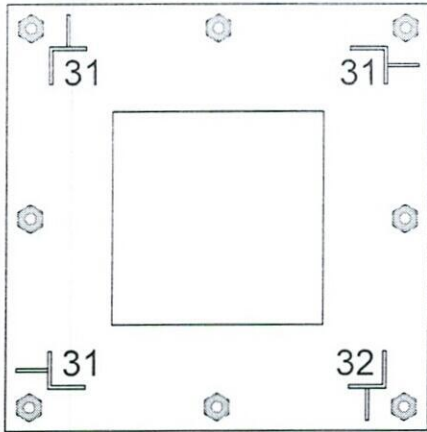

Section A-A  
PL80\*80\*0.8

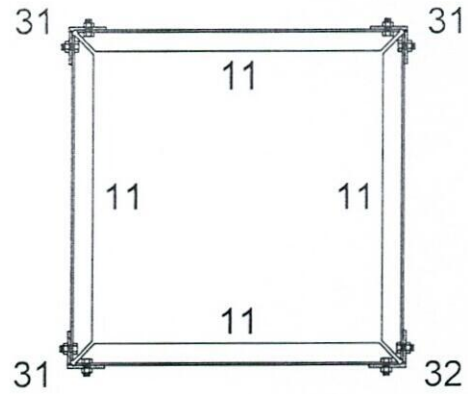

Section B-B

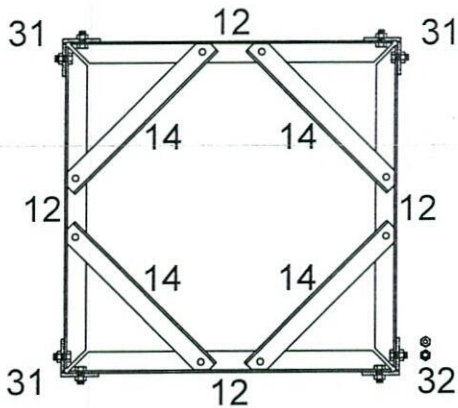

Section C-C

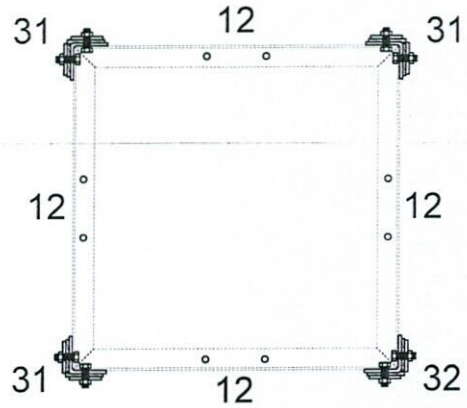

Section D-D

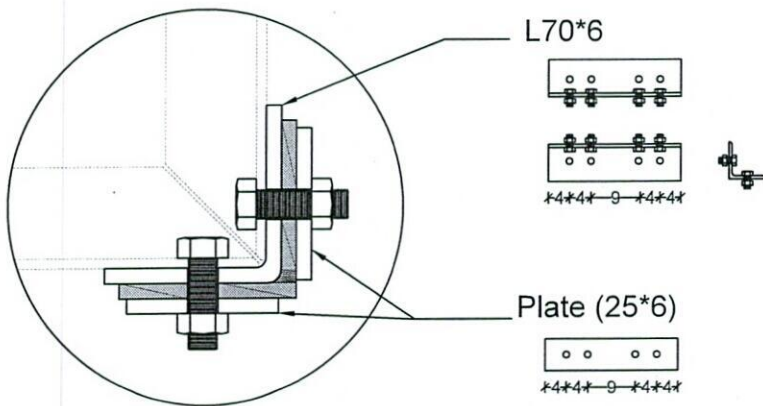

L70\*6

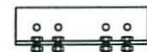
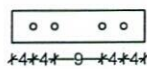

Plate (25\*6)



*Handwritten signature in blue ink.*



# Foundation For Cable - 2

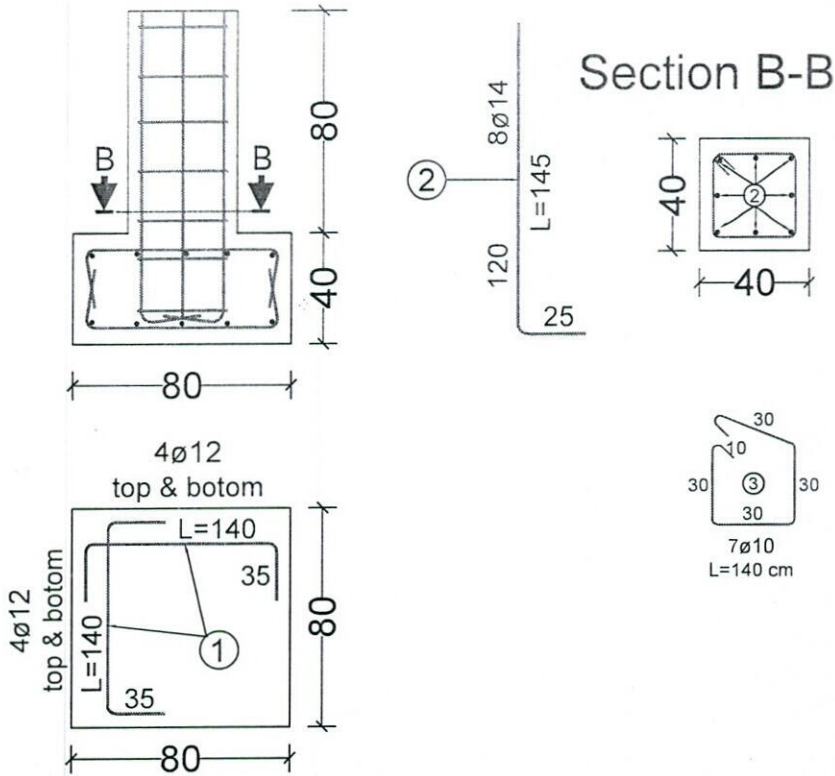

20m - Foundation For Cable -2 (For One Foundation)					
BAR TYPE	DIA (mm)	LENGHT (cm)	NO OF BARS	UNIT WT (kg/m)	TOTAL WT (kg)
1	ø12	140	16	0.89	19.94
2	ø14	145	8	1.21	14.04
3	ø10	140	7	0.62	6.08
TOTAL WEIGHT OF STEEL. (kg)					40
LEAN CONCRETE VOLUME. (Cu.m)					0.12
REINFORCED CONCRETE VOLUME. (Cu.m)					0.4
EXCAVATION. (Cu.m)					1.61
REINFORCEMENT STEEL.					S420
CONCRERE.					C20

*S.M.A.R.*

*[Handwritten signatures and initials]*



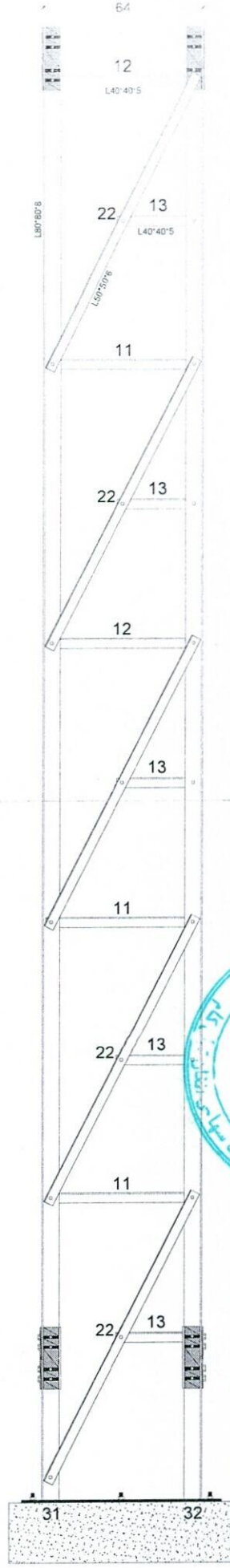
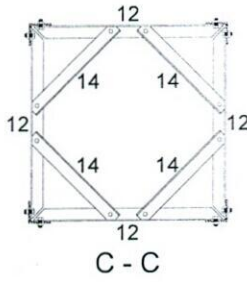
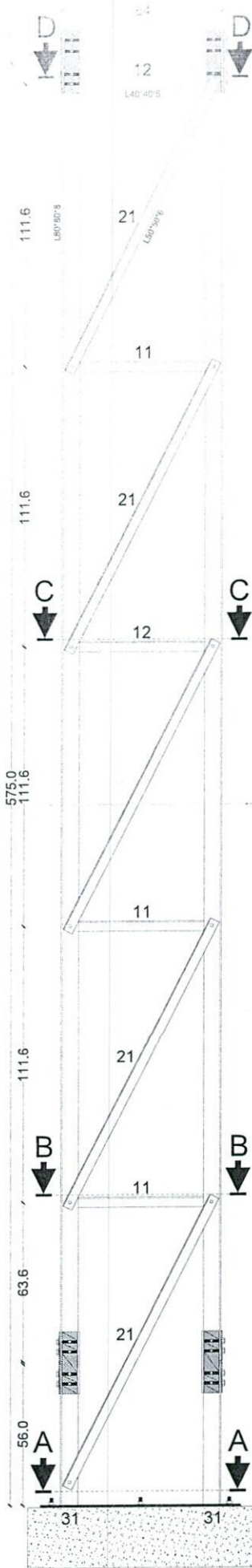

Section (1)



PROJECT:		25M GUYED MAST TOWER OF AFGHAN TELECOM			
TITLE:		TOWER DETAIL (BLOCK - 01)			
SCALE	DRAWN	DESIGNED	CHECKED	APPROVED	DATE
ORG. NO.	Salaam - TWR25GM - 01				REVISION



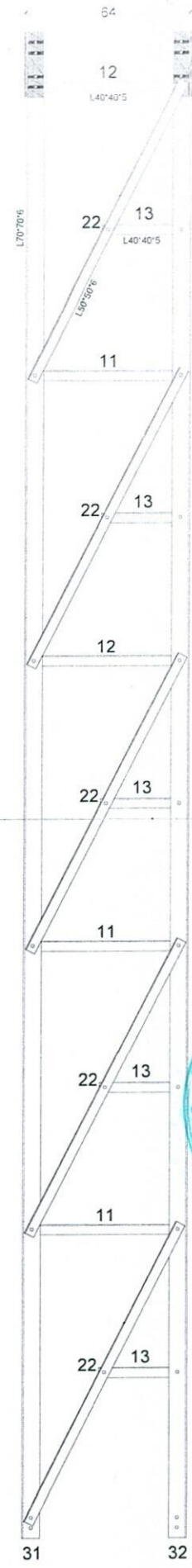
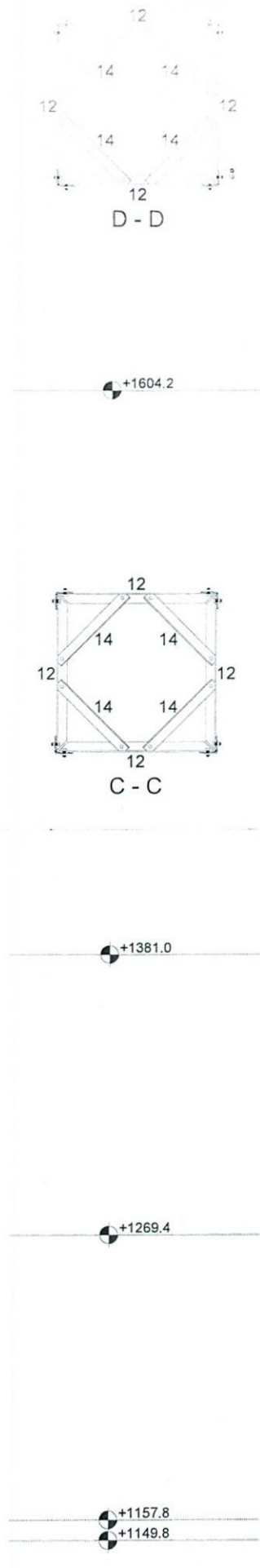
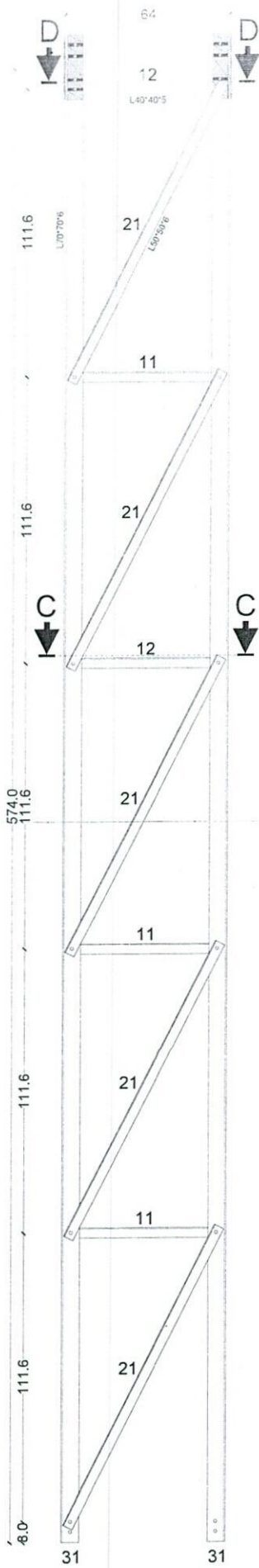

Section (3)



PROJECT:	25M GUYED MAST TOWER OF AFGHAN TELECOM			
TITLE:	TOWER DETAIL (BLOCK - 03)			
SCALE:	DRAWN	DESIGNED	CHECKED	APPROVED
ORG. NO.:	Salaam - TWR25GM - 03			
DATE:				REVISION:



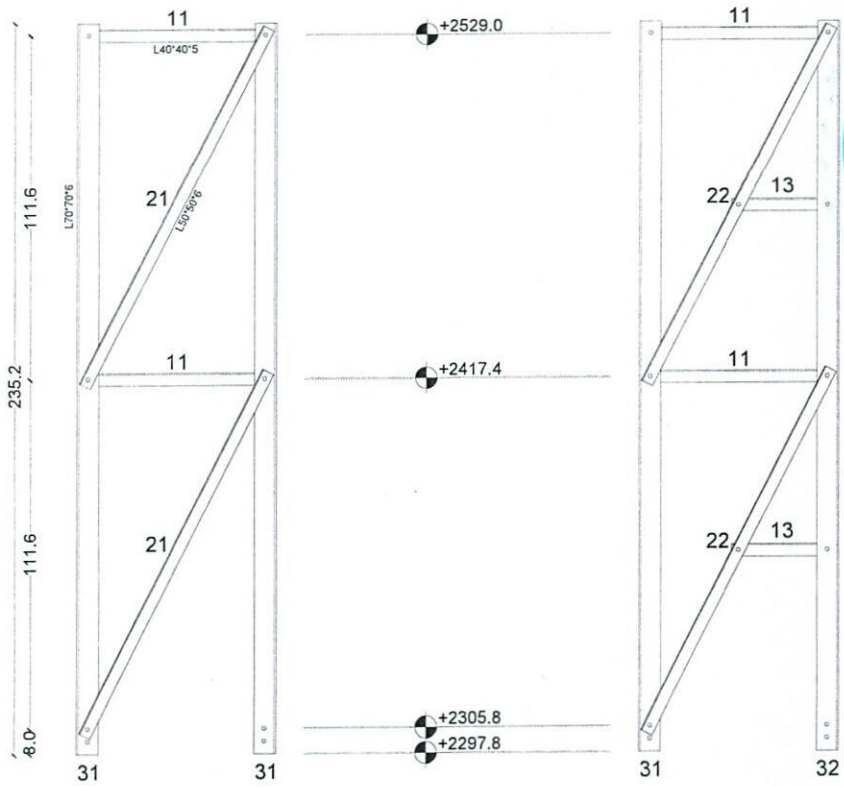

Section (5)

# Section Detail



Section A-A  
PL800\*800\*12

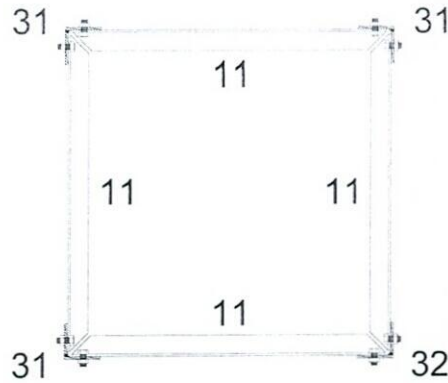

Section B - B

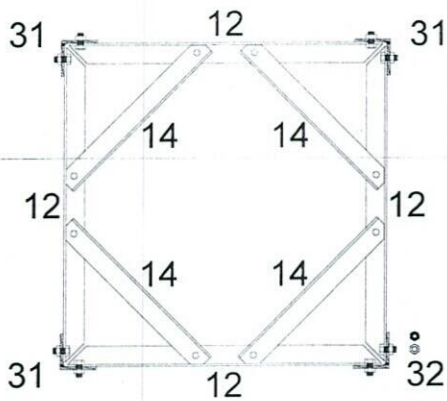

Section C-C & D-D

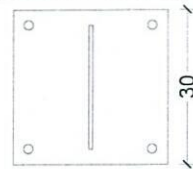
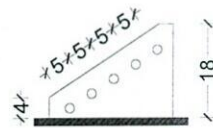
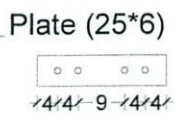
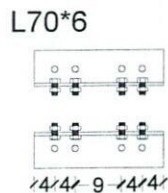
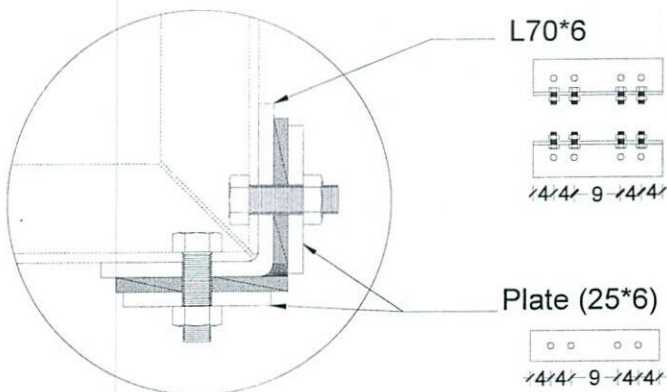

Plate Cable  
PL300\*300\*10



*[Handwritten signature]*

PROJECT:	25 GUYED MAST TOWER OF AFGHAN TELECOM			
TITLE:	TOWER SECTION DETAIL			
SCALE:	DRAWN	DESIGNED	CHECKED	APPROVED
ORG. NO.:	Salaam - TWR25GM - 06			
REVISION:				



# Guyed Tower Foundation -1

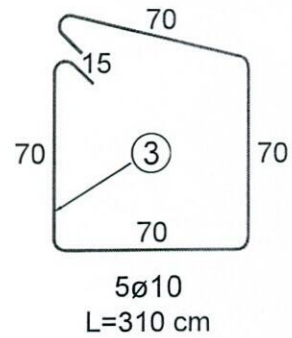
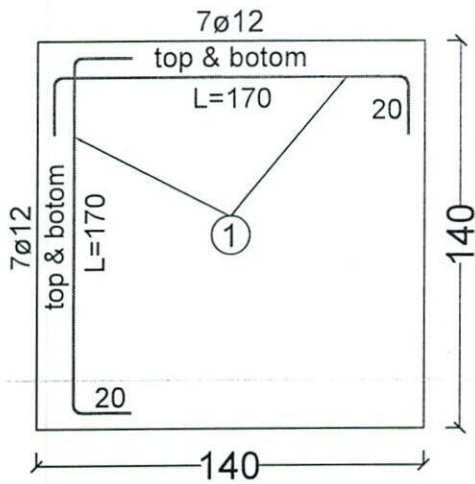
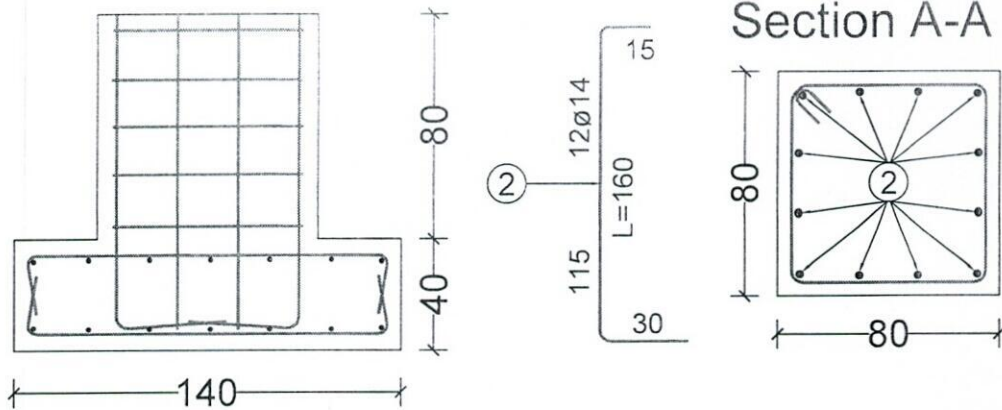

25m - Guyed Tower Foundation -1 (For One Foundation)					
BAR TYPE	DIA (mm)	LENGTH (cm)	NO OF BARS	UNIT WT (kg/m)	TOTAL WT (kg)
1	Ø12	170	28	0.89	34.18
2	Ø14	160	12	0.89	20.83
3	Ø10	310	5	0.62	13.45
TOTAL WEIGHT OF STEEL. (kg)					69
LEAN CONCRETE VOLUME. (Cu.m)					0.12
REINFORCED CONCRETE VOLUME. (Cu.m)					0.91
EXCAVATION. (Cu.m)					2.55
REINFORCEMENT STEEL.					S420
CONCRERE.					C20



*[Handwritten signature]*

# Foundation For Cable - 2

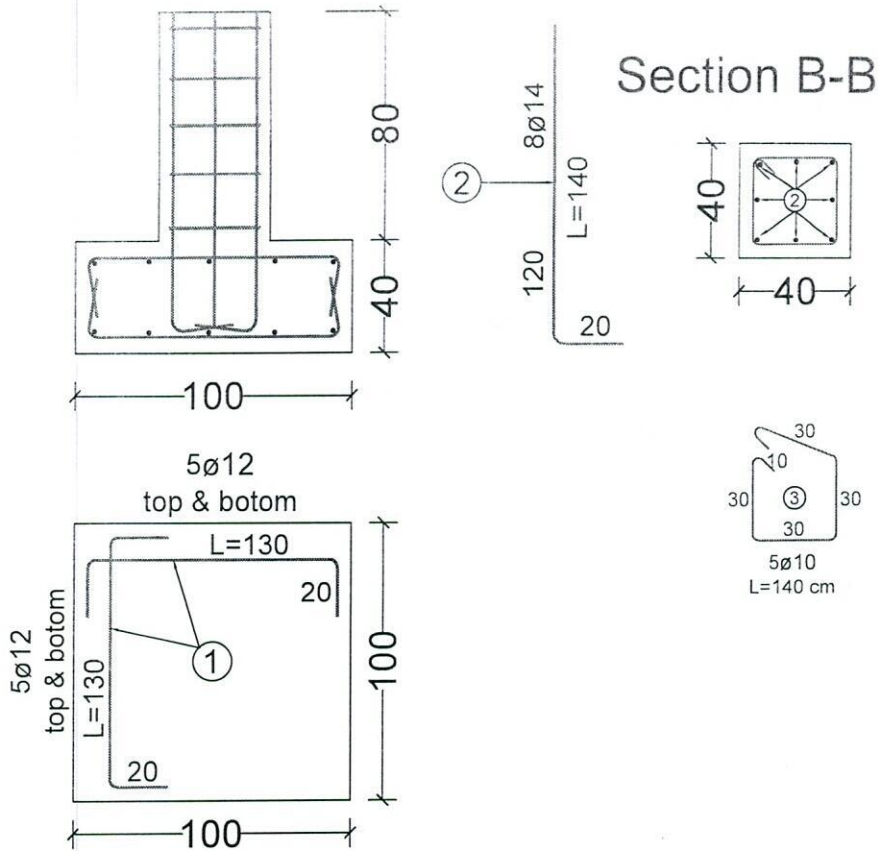

30m - Guyed Tower Foundation -1 (For One Foundation)					
BAR TYPE	DIA (mm)	LENGHT (cm)	NO OF BARS	UNIT WT (kg/m)	TOTAL WT (kg)
1	Ø12	130	20	0.89	19.94
2	Ø14	140	8	0.89	10.32
3	Ø10	140	5	0.62	6.08
TOTAL WEIGHT OF STEEL. (kg)					36
LEAN CONCRETE VOLUME. (Cu.m)					0.12
REINFORCED CONCRETE VOLUME. (Cu.m)					0.4
EXCAVATION. (Cu.m)					1.87
REINFORCEMENT STEEL.					S420
CONCRERE.					C20



*[Handwritten signatures and initials in blue ink]*